



DIGITAL CONTROLLERS WITH ONE 0-10 V OUTPUT AND ONE RELAY OUTPUT DB-R/3

FUNCTION

Regulation of 1 or 2 independent physical quantities with:

- 1 proportional output 0...10 Vdc;
- 1 relay output;
- 1 output for power supply of active transducer (17 Vdc, max 44 mA);

- 3 digit display;
- red led, output state indicator;
- push buttons for parameters setting;
- optical alarms;
- password and two access levels.

TECHNICAL DATA

Power supply:	see schedule on the following page
Input:	see schedule on the following page
Outputs:	1 proportional 0...10 Vdc ($R_L > 10 \text{ KOhm}$) 1 SPDT relay 8 A 230 Vac
Power cons.:	< 3 W
Range:	see schedule on the following page
Working:	0...+45 °C 10...90% r.h. (without condensing) <95% r.h.
Storage:	-20...+70 °C
Connections:	screw terminal block for cables up to 2.5 mm ²
Housing:	ABS fireproof plastic according to UL94 V-0
Protection:	IP52 (only front plate), class II
Size:	96 x 48 x 122 mm mounting hole: 92 x 45 mm
Weight:	400 g

WIRING DIAGRAM

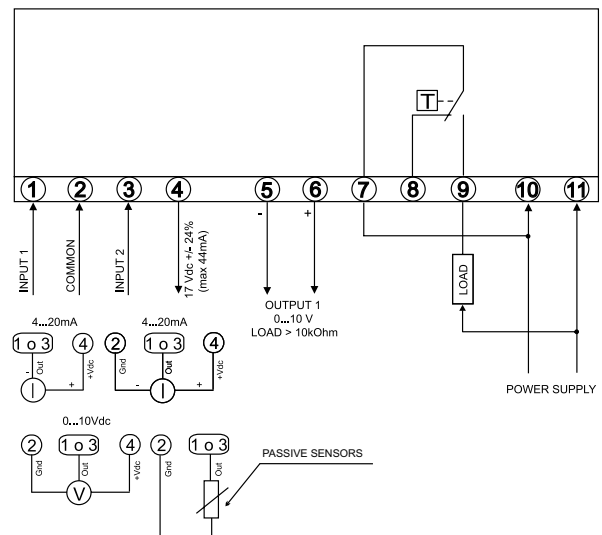

MOUNTING

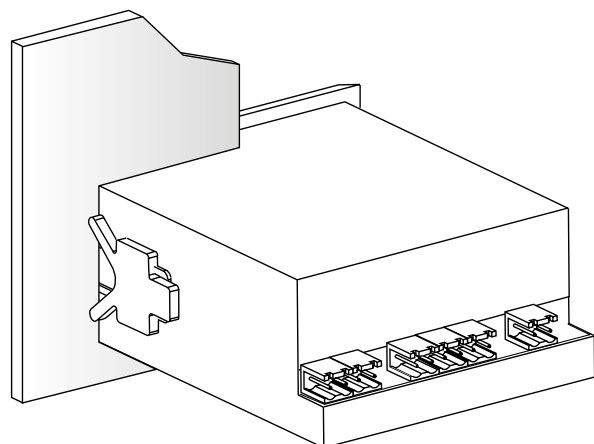

PART NUMBER SELECTION

	Input 1			Input 2				
	X	X	XX	X	X	XX	X	3
DB-R								
INPUT 1								
NTC10-02	1	1	07 ⁽¹⁾					
0...10 Vdc (**)	7							
4...20 mA (**) (R _n = 100 Ohm)	9							
UNIT 1								
°C		1						
% r.h.		2						
bar		3						
mbar		4						
Pa		5						
RANGE 1								
0...+50 °C			01					
-30...+50 °C			02					
-10...+40 °C			03					
0...+100 °C			04					
-20...+80 °C			05					
0...+100% r.h.			06					
-50...+110 °C			07					
-60...+600 °C			08					
-50...+150 °C			09					
-60/+200 °C			10					
Range on request (*)			99					
INPUT 2 ⁽²⁾								
None				0	0	00		
NTC10-02				1	1	07 ⁽¹⁾		
PT1000				2	1	08 ⁽¹⁾		
PTC 2K				3	1	09 ⁽¹⁾		
NI1000				4	1	10 ⁽¹⁾		
0...1000 ohm				5	2	06 ⁽¹⁾		
0...1 Vdc (**)				6				
0...10 Vdc (**)				7				
0...20 mA (**)				8				
4...20 mA (**)				9				
UNIT 2								
None						0		
°C						1		
% r.h.						2		
bar						3		
mbar						4		
Pa						5		
RANGE 2								
None							00	
0...+50 °C							01	
-30...+50 °C							02	
-10...+40 °C							03	
0...+100 °C							04	
-20...+80 °C							05	
0...+100% r.h.							06	
-50...+110 °C							07	
-60...+600 °C							08	
-50...+150 °C							09	
-60...+200 °C							10	
Range on request (*)							99	
POWER SUPPLY								
230 Vac ± 10% 50/60 Hz								1
12 Vac ± 10% 50/60 Hz								2
OUTPUT								
1 0-10 V and 1 relay SPDT 8 A, 230 Vac								

(*) to specify during the ordering process

(1) fixed ranges

(2) Input 2 only in addition with input 1. If the input 2 is different from "none", then the input 1 works with proportional output, input 2 works with the relay output. If only one sensor is used for both the output, use the sensor 1.

(**) working range can be chosen only for models with current (mA) or voltage (Vdc) inputs

