



VFL2/VFL3

2- and 3-way DIN-standard flanged valve

Control valves intended for use in heating, cooling and ventilation systems. They are intended to be used together with the SExx actuators. The valves have DIN-standard lengths.

- Size DN65...DN150
- Kvs value 52...300
- Rangeability 100:1
- Pressure rating PN16
- Media temperature -5...+120°C
- Face-to-face dimensions as per DIN
- Pressure balanced (2-way)

Function

2-WAY VALVE

Stem in the lower position, the valve is open between the ports A - AB. Stem in the upper position, the valve is closed between the ports A - AB.

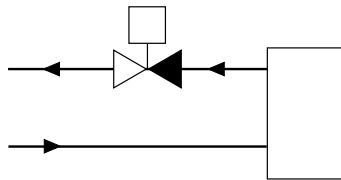

2-WAY VALVE

3-WAY VALVE

Stem in the lower position, the valve is open between the A - AB and closed between the ports B - AB. Stem in the upper position, the valve is closed between the ports A - AB and open between B - AB.

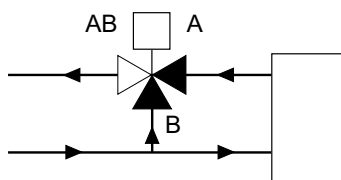

3-WAY VALVE

Installation

The 2-way valve should be mounted with port A on the inlet and port AB on the return (flow direction A in, AB out) to ensure that the plug closes tightly and to prevent any noise when closing.

The 3-way valve is of a mixing type and must therefore be mounted in the mixing point.

- Before installation of the control valve, ensure that the pipe is clean. Make sure that pipe scale, metal chips, welding slag and other foreign materials are removed.
- For maximum efficiency and minimum wear, install the valve in a vertical position with the stem pointing upward. If the valve is mounted with the actuator on the side, more wear is caused to the valve stuffing box. The valve should never be mounted at an angle of more than 90°.

MAIN OFFICE BRESSANONE

I-39042 Bressanone (BZ)
via Julius-Durst-Str. 70
VAT No. IT02748450216

tel: +39 0472 830626
fax: +39 0472 831840
www.industrietechnik.it

VFL2/VFL3

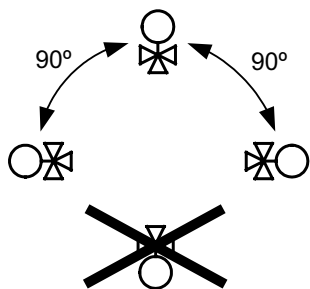

- Install the valve according to the fluid direction arrow shown on the valve.
- Make sure there is ample space above the valve to facilitate easy removal of the valve actuator.
- Adjust the connection between the valve and the counter flange to minimise the tension between them.
- Tighten the bolts crosswise, as shown in the picture below. Tighten one flange at a time. After conducting a test run, the bolts should be tightened crosswise once more.

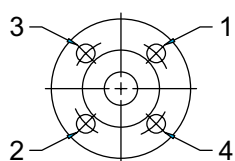

- Fit a strainer/filter upstream of the valve to prolong the equipment's life span.
- A water quality according to VDI 2035 is recommended.

MAIN OFFICE BRESSANONE

I-39042 Bressanone (BZ)
via Julius-Durst-Str. 70
VAT No. IT02748450216

tel: +39 0472 830626
fax: +39 0472 831840
www.industrietechnik.it

VFL2/VFL3

Technical data

Application	Heating systems, cooling systems, ventilation systems
Pressure rating	PN16
Connection	Flanged according to EN 1092-2
Flow characteristics	A → AB: 0-30 % open = linear, 30 - 100 % open = equal percentage B → AB: linear
Max. leakage	A - AB: DN65...DN80 = max 0.1 % of the kvs value, DN100...DN150 = max 0.2 % of the kvs value B - AB: Max 2 % of the kvs value
Media	Hot water, cold water, glycol-mixed water (max. 50 % glycol)
Media temperature	-5...+120 °C
Rangeability	100:1

Material

Body	Cast iron Grade 200
Plug	Stainless steel 1.4301
Seat	Cast iron Grade 200
Stem	Stainless steel 1.4301
Packing box	Brass CW 617N
Bonnet	Cast iron Grade 200
O-rings	EPDM
Packing	Aramid reinforced rubber

2-way valves

Article	Nominal diameter	Kvs	Stroke
VFL265-52	DN65	52 m ³ /h	20 mm
VFL80-79	DN80	79 m ³ /h	20 mm
VFL2100-124	DN100	124 m ³ /h	40 mm
VFL2125-200	DN125	200 m ³ /h	40 mm
VFL2150-300	DN150	300 m ³ /h	40 mm

3-way valves

Article	Nominal diameter	Kvs	Stroke
VFL365-52	DN65	52 m ³ /h	20 mm
VFL380-79	DN80	79 m ³ /h	20 mm
VFL3100-124	DN100	124 m ³ /h	40 mm
VFL3125-200	DN125	200 m ³ /h	40 mm
VFL3150-300	DN150	300 m ³ /h	40 mm

Combination options (valves and actuators) and differential pressure

Type	ΔPs (SE5F...)	ΔPs (SE10F...)	ΔPs (SE18F...)	ΔPs (SE25F...)
VFL265-52	800 kPa	1600 kPa	1600 kPa*	1600 kPa*
VFL280-79	800 kPa	1600 kPa	1600 kPa*	1600 kPa*
VFL2100-124	N/A	N/A	1600 kPa	1600 kPa
VFL2125-200	N/A	N/A	1600 kPa	1600 kPa
VFL2150-300	N/A	N/A	1600 kPa	1600 kPa
VFL365-52	100 kPa	200 kPa	400 kPa*	400 kPa*
VFL380-79	75 kPa	150 kPa	300 kPa*	300 kPa*
VFL3100-124	N/A	N/A	200 kPa	260 kPa
VFL3125-200	N/A	N/A	130 kPa	160 kPa
VFL3150-300	N/A	N/A	80 kPa	120 kPa

*The washer 02133011 is required in order to use the SE18F... or SE25F... actuators together with the DN65 or DN80 valves.

ΔPs constitutes the max. permitted differential pressure at which the valve actuator can safely close against the pressure.

MAIN OFFICE BRESSANONE

I-39042 Bressanone (BZ)
via Julius-Durst-Str. 70
VAT No. IT02748450216

tel: +39 0472 830626
fax: +39 0472 831840
www.industrietechnik.it

VFL2/VFL3

Dimensions

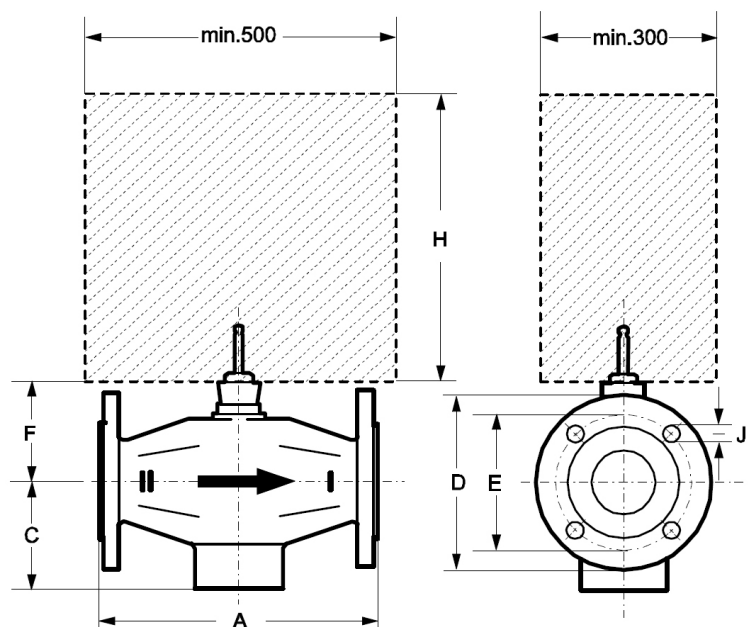

Type	DN	A	B	C	øD	øE	F	øJ	G	Hmin	Stroke	Weight (kg)
VFL265-52	65	290	140	134	185	145	106	19 (x4)	20	500	20	16.5
VFL280-79	80	310	150	144	200	160	107	19 (x8)	22	500	20	19
VFL2100-124	100	350	150	144	220	180	150	19 (x8)	24	500	40	27
VFL2125-200	125	400	170	162	250	210	165	19 (x8)	26	500	40	49.5
VFL2150-300	150	480	200	200	285	240	179	24 (x8)	26	500	40	66.5

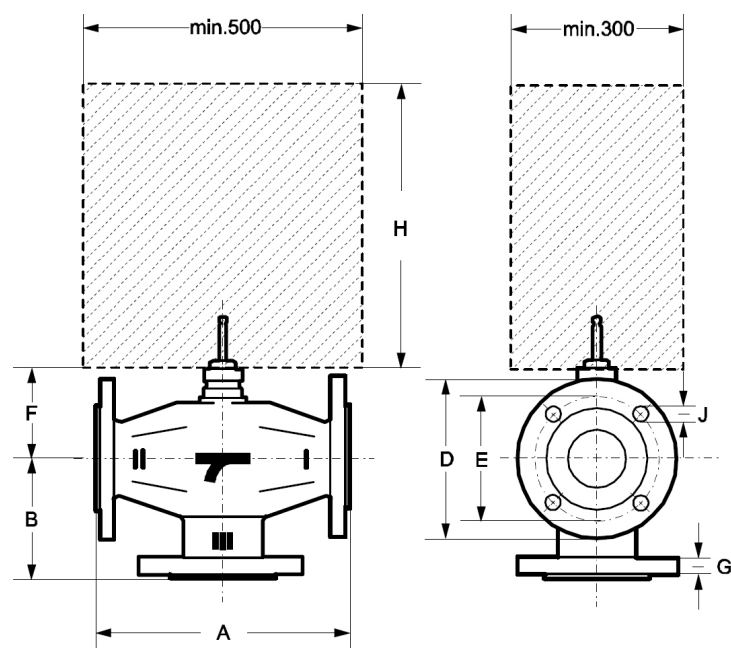

Type	DN	A	B	C	øD	øE	F	øJ	G	Hmin	Stroke	Weight (kg)
VFL365-52	65	290	140	134	185	145	106	19 (x4)	20	500	20	18.5
VFL380-79	80	310	150	144	200	160	107	19 (x8)	22	500	20	23
VFL3100-124	100	350	150	144	220	180	150	19 (x8)	24	500	40	31
VFL3125-200	125	400	170	162	250	210	165	19 (x8)	26	500	40	53
VFL3150-300	150	480	200	200	285	240	179	24 (x8)	26	500	40	69.5

Measurements in mm unless otherwise specified.

MAIN OFFICE BRESSANONE

I-39042 Bressanone (BZ)
via Julius-Durst-Str. 70
VAT No. IT02748450216

tel: +39 0472 830626
fax: +39 0472 831840
www.industrietechnik.it

VFL2/VFL3

Pressure drop curves

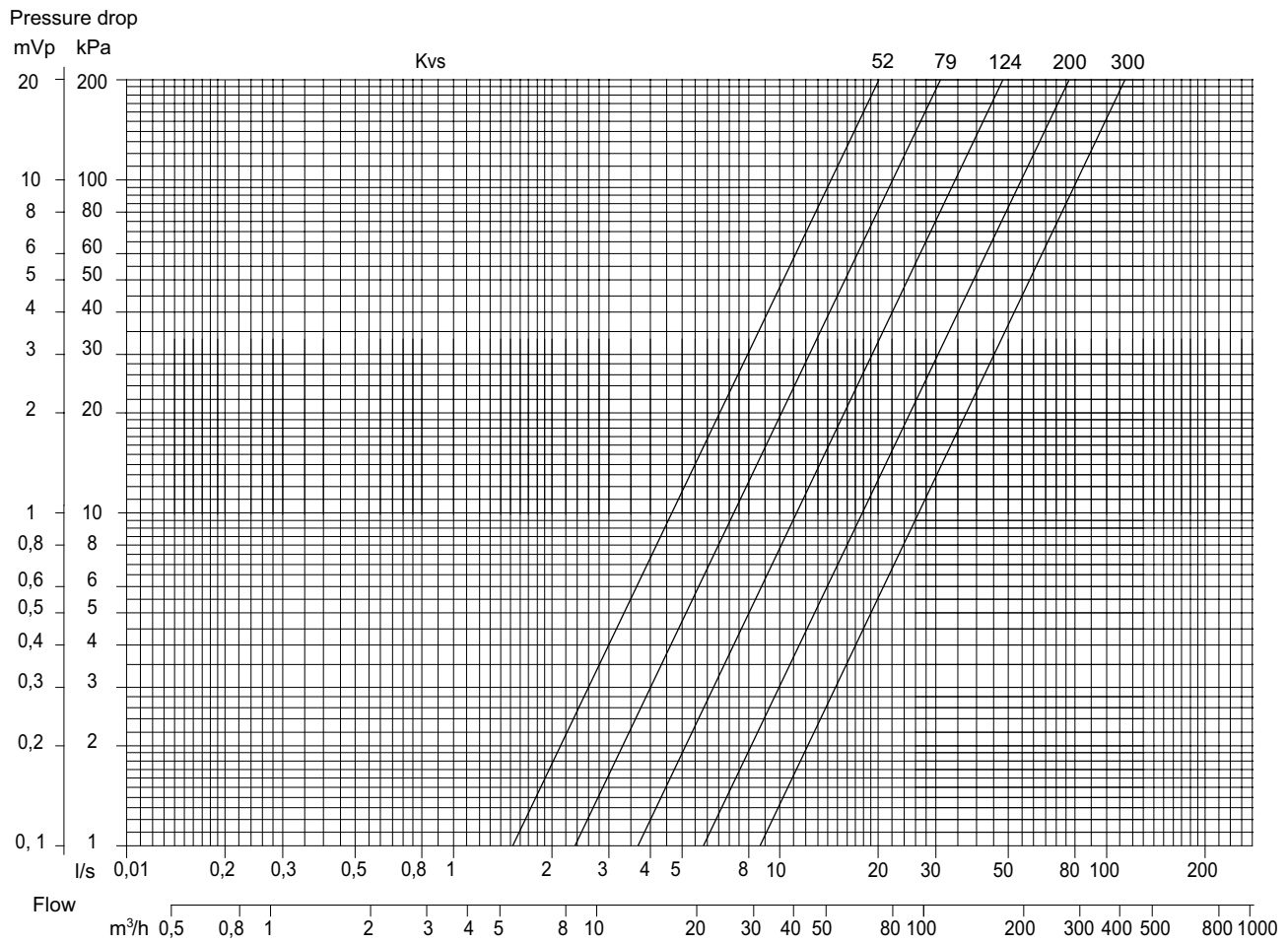

EXAMPLE: CALCULATION OF KV VALUE

If the pressure drop is 4 kPa (A) and the flow is 40 m³/h (B), the kv value is 200 (C). See the markings in the picture to the right.

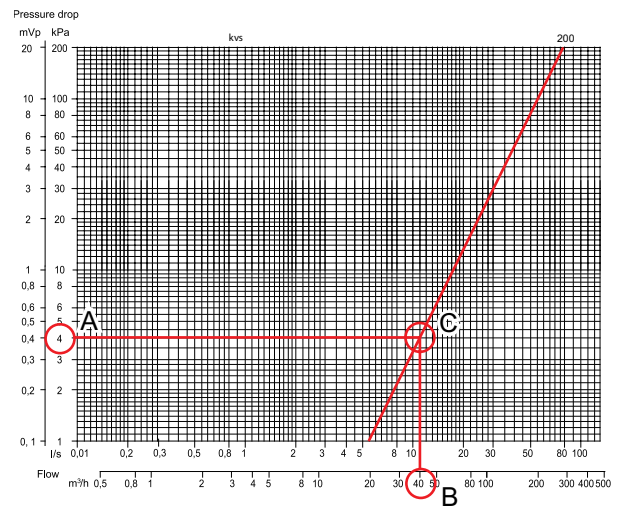

.....

MAIN OFFICE BRESSANONE

I-39042 Bressanone (BZ)
via Julius-Durst-Str. 70
VAT No. IT02748450216

tel: +39 0472 830626
fax: +39 0472 831840
www.industrietechnik.it

VFL2/VFL3